



FEATURES

State of the art, ergonomic and high speed. Air blows down from vents on top, preventing water splashback and achieving fast drying time. Ultra hygienic Super Filter* system eliminates 99% of airborne bacteria. Water is pushed back onto an absorbent and continuously evaporating ceramic plate. Water not evaporated or absorbed is channelled into a drip tray (not the floor). Can only be removed using a dual step security system offering enhanced vandal resistance.

*We recommend changing the Super Filter every 6 months based on normal use (for dusty and extremely heavy use we recommend changing the Super Filter every 3 months). The part number for the Super Filter is: 10-A0194

INSTALLATION OPTIONS

Electrical connection by cord & plug (as supplied). Can be direct wired by an electrician.

SPECIFICATION

- Electrical Supply: AC, 220-240V 50/60Hz, 1600W
- Motor: 1 HP Brush Type, Dual Ball Bearings
- RPM: 11,000 – 18,000 (adjustable)
- Element: 400 - 900 Watt (adjustable)
- Air Volume: 55 – 88 CFM (89 – 124m³/h) (adjustable)
- Noise Level: 63 – 67 dB-A @2M
- Weight: 10.8kg, Shipping 12.8kg
- Drying Time: Approx 12 seconds
- Certificate of Suitability No: GMA-500003
- Electrical Safety Requirements: AS/NZS 60335.2.23:2004
- Protection Category: IPX1

FINISH

Grey, ABS

RECOMMENDED INSTALLATION HEIGHT (Above Finished Floor - from top of hand drying chamber)

Men's washroom	1150mm
Women's washroom	1080mm
Children's washroom ages 4-7	780mm 
Children's washroom ages 8-10	880mm
Children's washroom ages 11-13	965mm
Children's washroom ages 14-16	1080mm
Accessible Compliant washroom	900mm

WARRANTY

5 years.

Tri-Umph Grey shall be Model No. 10-20200-2 as manufactured by ASI JD MacDonald.

 All ASI JD MacDonald disabled compliant products, when installed, must be in accordance with AS1428 to ensure the specified product is complying with all washroom specification requirements.

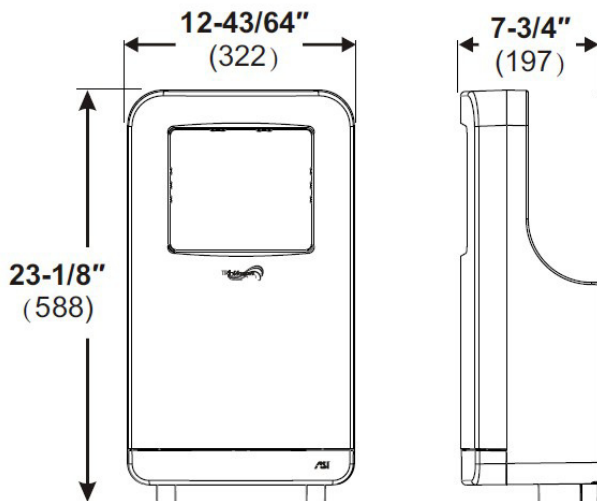

ASI JD MacDonald reserves the right to, and does from time to time, make changes and improvements in design and dimensions. The photographs and line drawings of the products in this flyer are representational only. All dimensions are in millimetres unless otherwise stated.