

# HAND DRYERS



## ML\_1800\_WHT

Automatic Operation ABS Hand Dryer

### Specification

Casing	3.0mm White High Grade Fire Retardent ABS
Motor	80W Brushless, 2850 RPM 105°C auto reset overload
Power Use	240V, 50Hz, 1800W, 7.50A
Sound Level	55db (+/- 3)
Drying time	30-35 seconds
DP Rating	IPX 1
Heater	87°C auto resetting thermostat 141°C auto reset safety cut off
Warm Air	Speed: 14.5m/s Temp: Ambient +20°C
Protection	60 sec power cut off, auto reset
Timing	2 sec delay turn off after last read
Sensor/Range	Auto Infrared - 180mm +/-20mm preset, 100 - 300mm adjust
Case Security	2 SS theft resistant hex drive screws (hex key supplied)
Net Weight	3.5kg
Dimensions	259.99W x 216.99H x 179.99D
Warranty	5 Year Warranty (3 Years Parts and Labour + 2 Years Parts only)
Note	Unit can be hard wired by electrician or used with cord and plug provided * This unit is accessible compliant when installed in accordance with AS1428.1. guidelines.

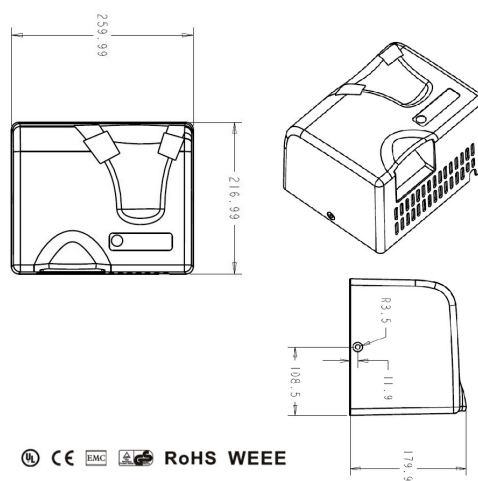

### Downloads & Resources

- Care & Maintenance
- Mounting template
- Revit
- Promotions

*The photographs and line drawings of the products presented above are representational only. Metlam Australia Pty Ltd reserves the right to, and from time to time, make changes and improvements in design and dimensions.*